

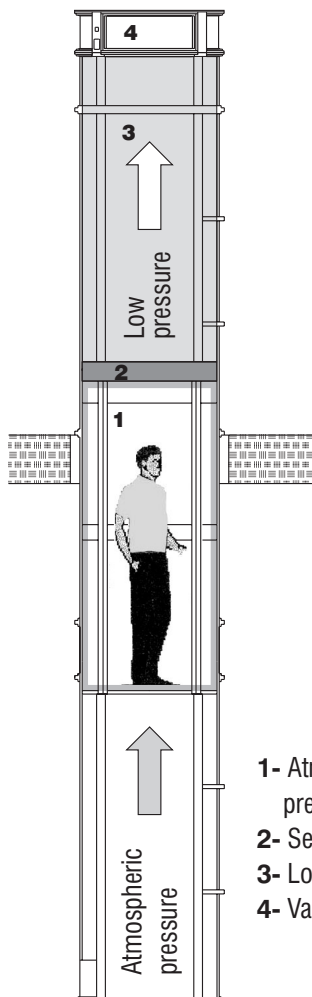

- Power supply** 220 VAC - 60 Hz
- Motor Power** 4,5 Kw
- Size**
 - a) External cylinder diameter: 37" (95 cm)
 - b) Internal Cabin diameter: 32" (82 cm)
 - c) Internal cabin height: 77" (195 cm)
- Total Weight** 800 lbs (For 10' ceiling)
- Lift Capacity** standard model can carry up to 450 lbs
- Velocity** 6 Inches/Second (15cm/sec.) or 30'/min (9m/min).
- Illumination** halogen lights
- electrical circuits** 24-volt
- lubrication** not required
- Installation** no excavation or shaft required. Elevator rests on floor. self supported
- Safety** pressure switch; on free fall elevator brakes within 2 inches; on electricity cut elevator automatically descends to ground floor; alarm system in cabin; emergency ventilation; door safety switches; telephone (optional)
- Warranty** one year on parts and labor

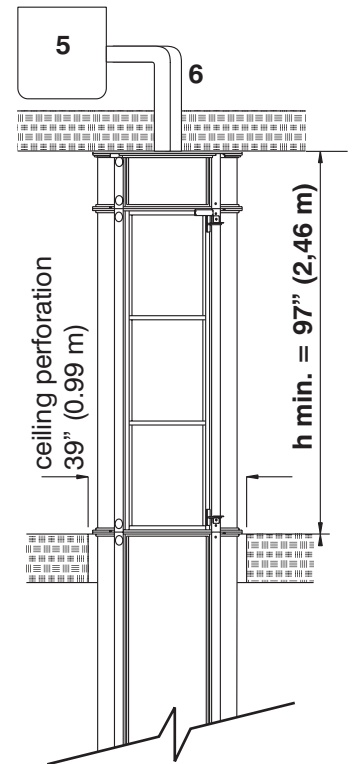

- 1- Atmospheric pressure zone
- 2- Seal on cabin
- 3- Low pressure zone
- 4- Vacuum pump

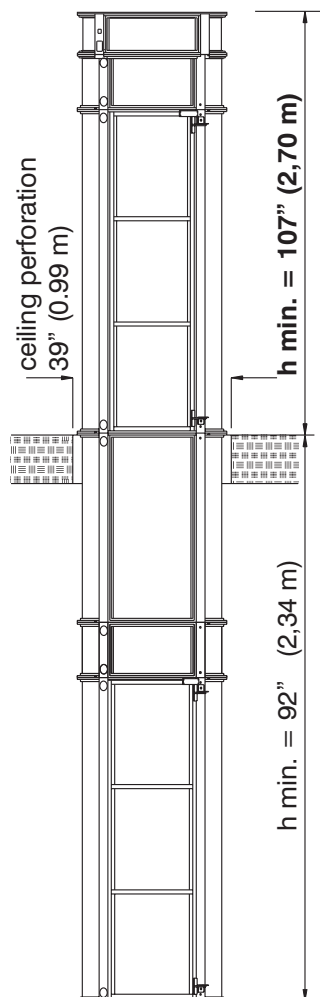

SPLIT model

- 5 - Vacuum pump's box
29" x 18" x 21"
- 6 - PVC's pipes \varnothing 4 1/2"